

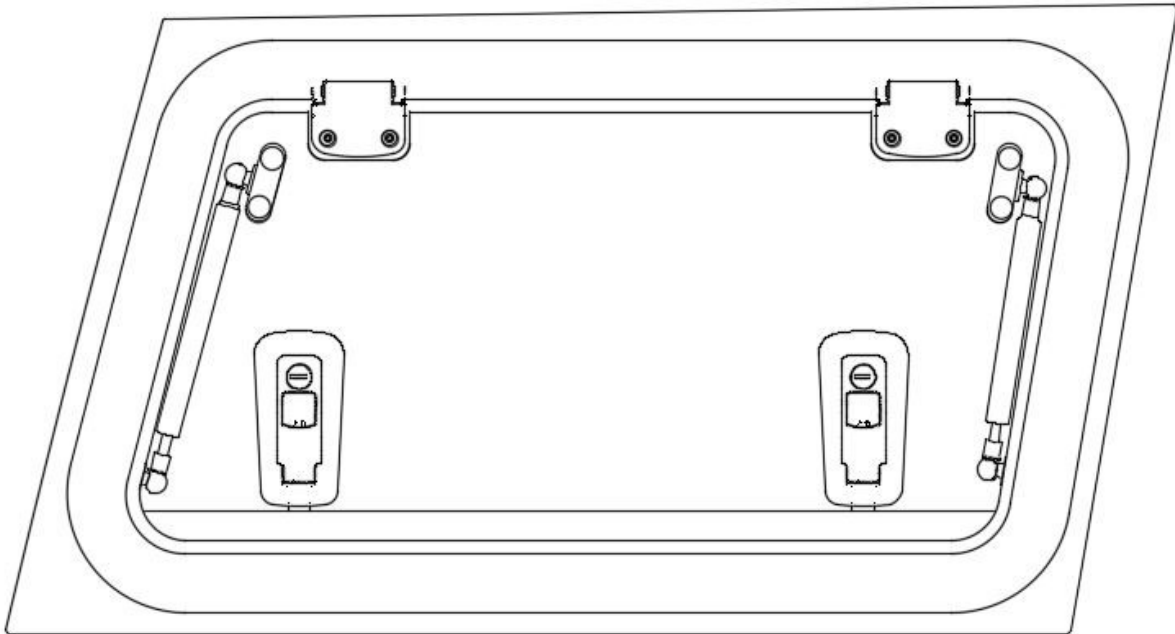

Removal and installation sliding and expedition windows Jeep Cherokee XJ



Required materials:

- Disassembly tools or screwdrivers (see figure 1)
- Suction cup
- Masking tape
- Alcohol
- String
- Soap water
- Work table
- Help from a friend



Figure 1 Disassembly tools

We strongly recommend that you read the manual in advance and watch our installation video on our You Tube channel: <https://youtu.be/CGYfigBBwv8>

It is important that the Explore Glazing products are assembled correctly and safely. Careless assembly can lead to accidents and serious damage and / or injury to you or others. If you have no technical experience or are not familiar with the general assembly instructions, we recommend that you have our products assembled by a professional company.

Removal of the original window

1. Remove the inner lining so that you have free access to the side window of the car.
2. Cover the body surface on the outside of the window with masking tape to prevent damage during work.
3. Place a number of disassembling tools in one corner of the window, between the rubber and body to lift the rubber.
4. Place the suction cup on the outside of the window.
5. With the help from a friend, you can now remove the window:
One person should hold the suction cup on the outside to pull out, while the other pushes the glass out from the inside. See figure 2 as an example.

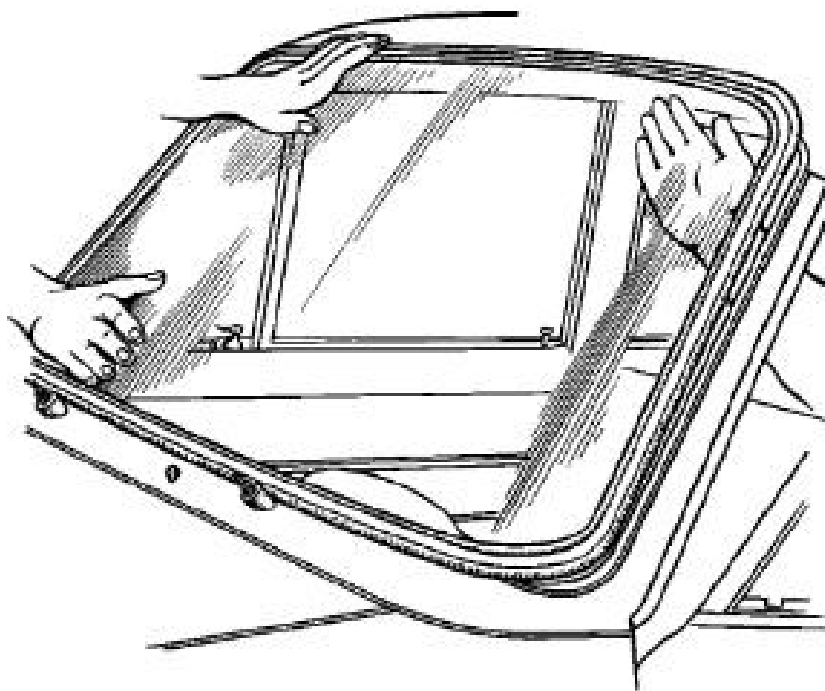

Figure 2 example of removing an existing glass pane in a rubber profile

6. Take a good look at how the original rubber is placed on the existing window and make sure that this rubber will be applied to the new window in the same way.

Installation of the new Explore Glazing sliding or expedition window

1. Clean the flange thoroughly with alcohol and check the condition of the flange. In case of rust, it must be treated with a primer.
2. The original rubber must be cleaned thoroughly. After cleaning the rubber, you will place the rubber on the new window.
3. You now moisten the rubber on the outside with some soap water. You can also lightly moisten the flange with soapy water to make the installation of your new window easier.
4. Place the string around the rubber, by starting at the top of the new sliding- or expedition window. Overlap the string at the bottom of the window by approximately 30 centimetres.
5. With some help you can now place the window in the body of the car. Make sure that the string is on the inside of the vehicle. (see figure 3)

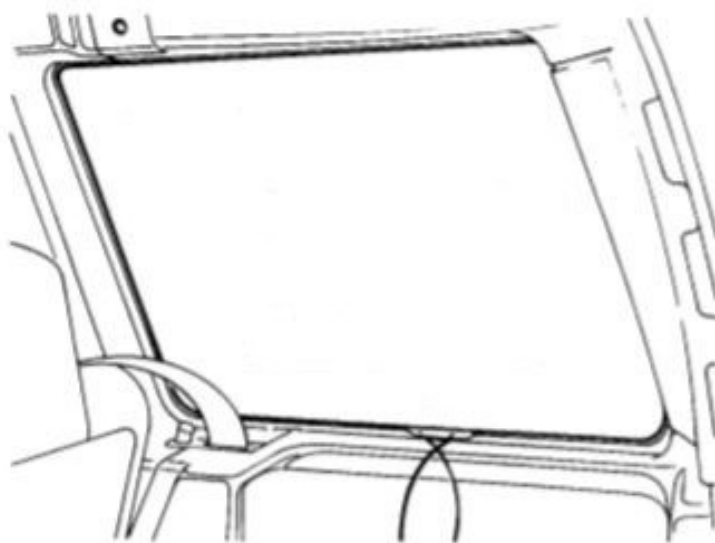

Figure 3 Position string on the inside of the car

6. Have someone put some light pressure on the edges on the outside of the window and then slightly pull on one side of the string on the inside of the car, so that the rubber lip is placed on the inside of the body again.

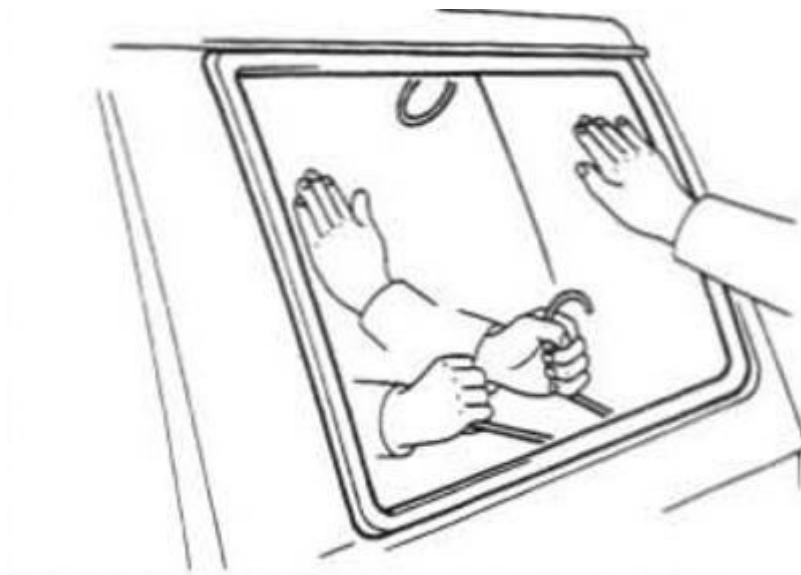

Figure 4 removing of the cord

7. Remove the string evenly, applying pressure from the outside at the same time, past the first corner and halfway through the window (vertically). Now you work in exactly the same way the other side.

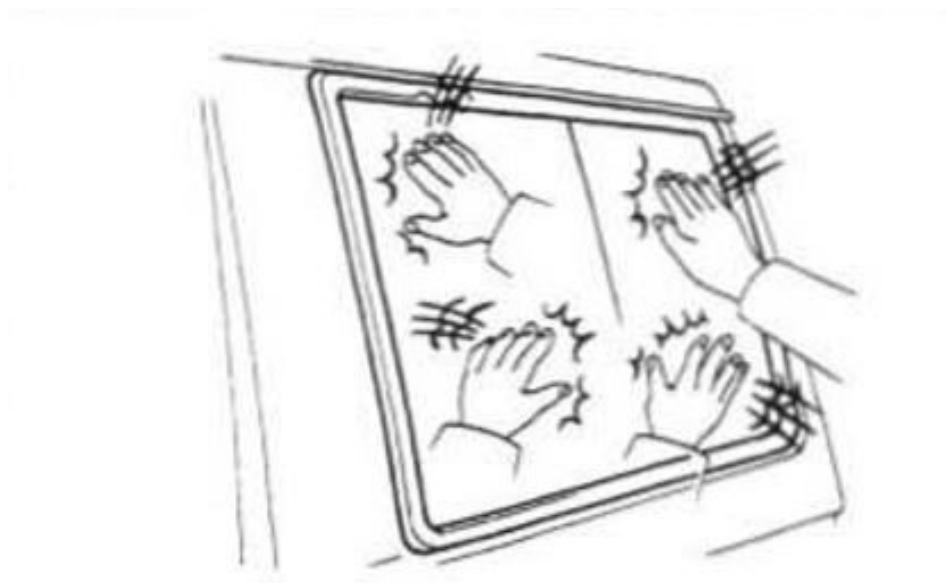

Figure 5 Working method

8. After the string has been completely removed, check that the rubber is correctly mounted. If it has not been mounted correctly the process may need to be repeated.
9. Replace the inner lining and your new window is mounted.